

OPERATION MANUAL

JENCO MODEL 378

Indicating temp. controller

JENCO ELECTRONICS, LTD.

MANUFACTURER OF PRECISION INSTRUMENTS

GENERAL INTRODUCTION

The Model 378 is a high performance industrial grade digital indicating single set point PROPORTIONAL /ON-OFF controller for use with type K, J, T and E thermocouple. Thermocouple gain and cold junction are automatically compensated by internal electrode circuits.

An accurate 1 mV per display count analog is provided to interface the instrument with a recorder, printer and so on.

INITIAL INSPECTION

Carefully unpack the instrument and accessories. Inspect for damage in shipment. If any damage is found. NOTIFY YOUR JENCO REPRESENTATIVE IMMEDIATELY. All packing materials should be saved until satisfactory operation is confirmed.

Specification

model	type	range	resolution	accuracy
378KC	K	0 to 1000°C	1°C	± 0.50% ± 1 count
378KF	K	0 to 1999°F	1°F	± 0.50% ± 1 count
378JC	J	0 to 550°C	1°C	± 0.40% ± 1 count
378JF	J	0 to 1000°F	1°F	± 0.40% ± 1 count

On/off control

Hysteresis: °C model 6°C (± 3°C)

 °F model 10°F (± 5°F)

Proportional control

Proportional band	Adjustable from on/off to 100°C or 100°F with built_in hysteresis
Cycle time	20 ± 3 second
Reset	Manual adjust

General

Operating temp.	0 to 40 °C
Analog output	1 mV/count, ± 0.30% of span ± 1 mV
T/C burnout	Upscale
Output relay	8 A at 115 VAC, 4A at 230 VAC, resistive load
Power source	115/230VAC , ± 10% 50/60 Hz
Dimension	96mm X 48mm X 105mm
Weight	0.38 kgs

Mounting procedure

1. Make a cutout on any panel, with a thickness of 1/16 inch(1.5mm to 3/8 inch(9.5mm)). Refer to drawing 1.
2. Remove the mounting brackets assembly from the panel meter and insert the panel meter into the cutout. Refer to drawing 2.
3. Replace the mounting brackets assembly onto the panel meter and fasten the mounting screws to secure the panel meter to mounting panel .Refer to drawing 3.

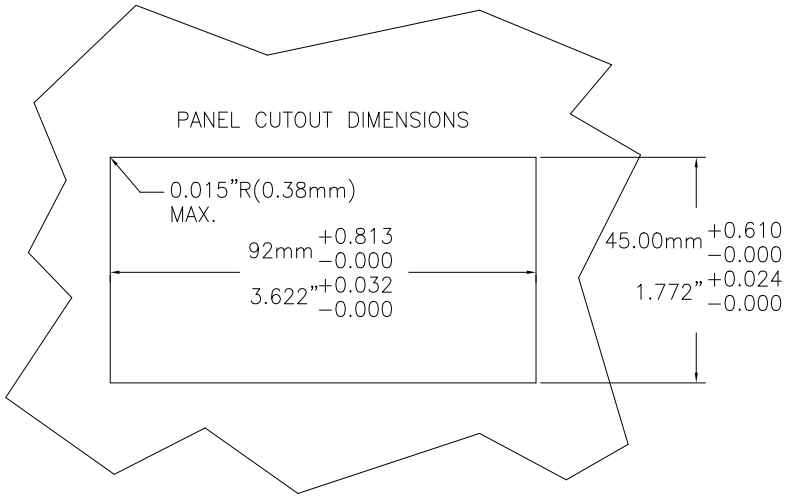

Panel cutout
Drawing 1

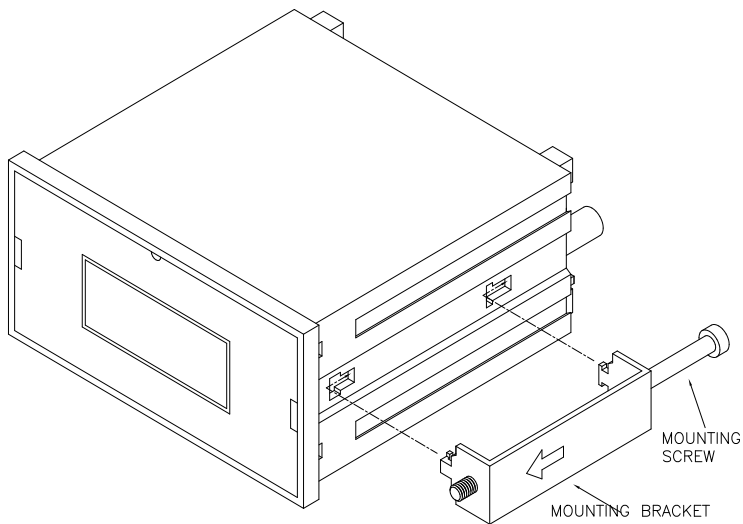

Panel meter with mounting bracket and screw

Drawing 2

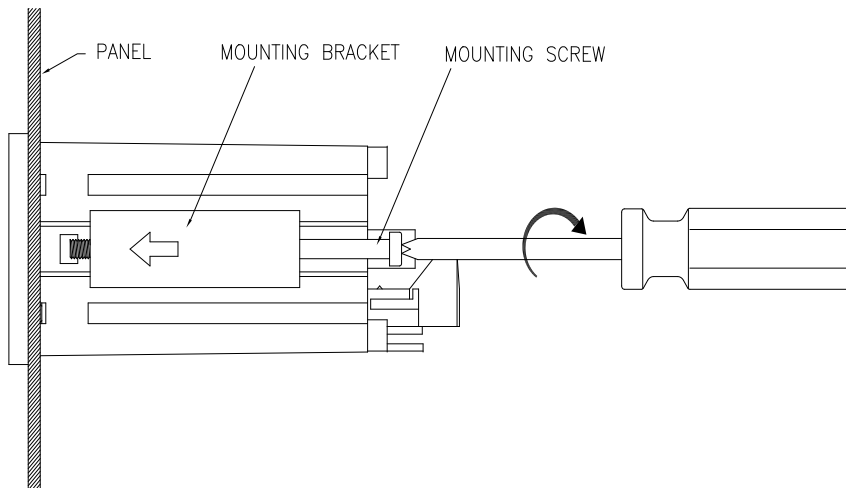

Mounting method
Drawing 3

Wiring diagram

- 1.Connect the AC line to the rear of the instrument . The model 378 can be used with 115/230 VAC 50/60Hz. Refer to drawing 4.
- 2.Connect the two thermocouple leads to the rear of the instrument .Be sure to observe the correct polarity of the thermocouple leads. Refer to drawing 4.

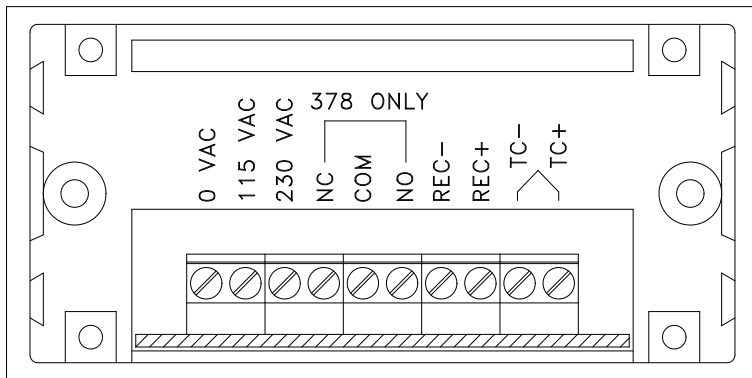

Wiring diagram
 Drawing 4

Analog voltage output

The analog voltage output can be used to interface with instruments such as recorder, printer, remote indicator, 4 to 20 mA converter, etc.

The following rule must be observed in order to avoid reading inaccuracies or possible damage to the instrument.

1. If grounded or naked thermocouple is used. The interface device's circuit common mustn't be connected to earth ground.
2. The input impedance of the interface device must be greater than 10 K Ohms.
3. Be sure that the AC line voltage is never connected to the analog output.

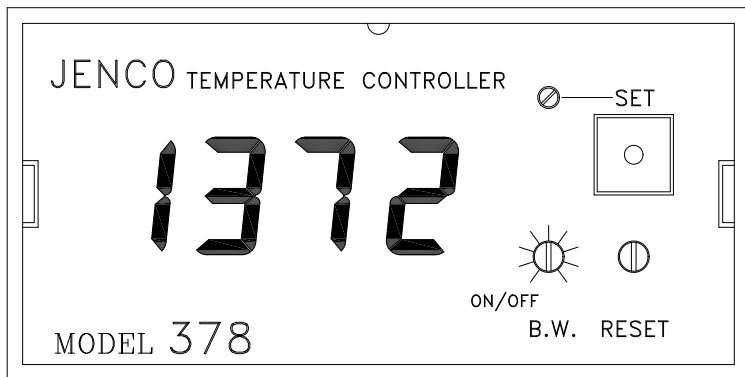

Front panel
Drawing 5

Controller action

The Model 378 is a single set point Proportional/On-off controller. The proportional bandwidth is adjustable from On-off to 100°C or 100°F with built_in hysteresis. The cycle time is factory set to 20 second \pm 3 seconds, Refer to drawing 6 for proportional controller timing.

Bandwidth adjust

Set the B.W. adjust control on the front panel to the desired Proportional Bandwidth. The controller action will be On-off when the B.W. adjust control is fully counter clockwise. Refer to drawing 5.

Controller set and reset

1. Press the Set point switch on the front panel .The meter indicates the temperature value of the set point. Refer to drawing 5.
2. Adjust the Set control on the front panel for the desired temperature value.
3. Release the Set point switch , the meter again indicates the process temperature value.
4. The process temperature may settle at any value within the proportional band.
5. Adjust the Reset control clockwise if the process temperature is less than the set temperature. The Reset control is disengaged for On/off control.
6. Repeat 5 until the process temperature is equal to the set temperature .

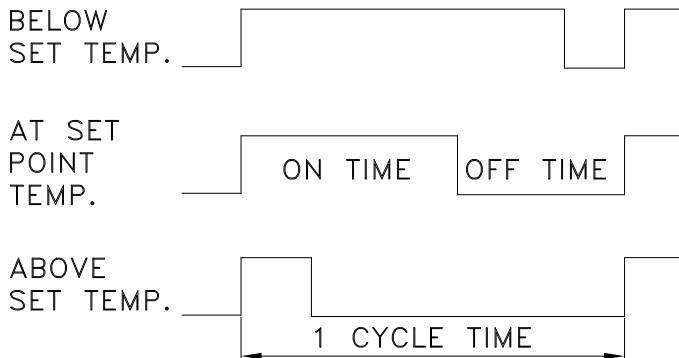

**Proportional controller timing
Drawing 6**

Relay and front panel led format

- 1.Connect the heater circuit to the N.O. and COM terminals of the relay. Make sure that the load doesn't exceed the rating of the relay, 8 A at 115VAC and 4A at 230VAC. The relay rating is for resistive load only.
- 2.The led on the front panel will be On when the relay is energized .Power is delivered to the heater through the N.O. and COM terminals of the relay.

Thermocouple burn out protection

The thermocouple burn out normally would result in an open circuit. The meter will be roll up scale, exceeding the set point and deenergized the relay. Power to the heater will be cut off.

WARRANTY

Jenco Instruments, Ltd. Warrants this product to be free from significant deviations in material and workmanship for a period of 1 year from date of purchase. If repair or adjustment is necessary and has not been the result of abuse or misuse, within the year period, please return-freight-prepaid and the correction of the defect will be made without charge. If you purchased the item from our Jenco distributors and it is under warranty, please contact them to notify us of the situation. Jenco Service Department alone will determine if the product problem is due to deviations or customer misuse. Out-of –warranty products will be repaired on a charge basis.

RETURN OF ITEMS

Authorization must be obtained from one of our representatives before returning items for any reason. When applying for authorization, please have the model and serial number handy, including data regarding the reason for return. For your protection, items must be carefully packed to prevent damage in shipment and insured against possible damage or loss. Jenco will not be responsible for damage resulting from careless or insufficient packing. A fee will be charged on all unauthorized returns.

NOTE: Jenco Instruments, Inc reserves the right to make improvements in design, construction, and appearance of our products without notice.

JENCO INSTRUMENTS, INC.

7968 Arjons Drive, Suite C San Diego, CA 92126 USA

TEL: 001-858-5782828 FAX: 001-858-5782886

E-MAIL: jencoi@ix.netcom.com; sales@jencoi.com

JENCO ELECTRONICS, LTD.

P.O. BOX 117 Jhong Jheng RD, Linkou Shiang, Taipei Hsien, TAIWAN

TEL: (886-2)2601-6191 FAX: (886-2)2601-7206

E-MAIL: jencoe@ms2.hinet.net

SHANGHAI JENCO ELECTRONICS, LTD.

18 Wang Dong Zhong Road, Sijing Town, Songjiang SHANGHAI, CHINA

TEL: (86-021)5761-9599 FAX: (86-021)5761-9598

E-MAIL: jencos@jenco.com.cn

Website: www.jenco.com.cn

使用说明书

机型	378	编制人	周悦来	编制日期	2008/09/19
文件编号	K378-02	修改人	杨启娜	修改日期	2009-6-31
版本号	03	核准人		核准日期	

修改记录：内容、原因及版次

08-9-19：由周悦来完成，完成日期为 2008/09/19

09-6-31：修改 EMAIL 地址信息

09-7-31:改插图，原图纸印刷模糊